

Ab Initio SCF-MO Calculations of Methyl lithium and Related Systems. Absence of Covalent Character in the C-Li Bond¹

Andrew Streitwieser, Jr.,* James E. Williams, Jr., Spiro Alexandratos, and John M. McKelvey

Contribution from the Department of Chemistry, University of California, Berkeley, California 94720. Received January 10, 1975

Abstract: SCF calculations are reported for CH₃Li using several basis sets. The largest basis set used, split shell with d orbitals on carbon (SS+d), gives an optimized geometry of $r(\text{C-Li}) = 2.021 \text{ \AA}$, $r(\text{C-H}) = 1.089 \text{ \AA}$, and $\angle\text{HCH} = 105.8^\circ$, with an energy of -47.0206 au . Electron density and projection plots as well as integrated electron populations show that the C-Li bond has essentially no shared-electron covalent character. Monomeric methyl lithium is described in terms of largely ionic bonding with about 0.8 e transferred from Li to CH₃. Similar calculations are described for ethyllithium, vinyl lithium, and ethynyllithium.

Organolithium compounds are important reagents, of widespread use in preparative organic chemistry.² Yet the nature of the carbon-metal bonding in these, the simplest organometallic compounds, does not appear to be well understood. Lithium, a highly electropositive alkali metal, is expected to form highly ionic bonds with less electropositive elements. Organolithiums are often considered as the lithium salts of the corresponding carbon acids, are taken to be good models for the corresponding carbanions,³ and in many reactions display a high degree of R⁻Li⁺ ionic character.⁴ The high ionicity of methyl lithium monomer has been inferred from its ir spectrum.⁵

Numerous other data, however, appear to indicate a large nonionic component in carbon-lithium bonds. NMR studies indicate that the charge separation in typical organolithiums is substantially less than unity.⁶ Many organolithium compounds, especially the alkyl lithiums, form oligomers whose structures are those of electron-deficient molecules with bridging organic moieties, rather than ionic aggregates or crystals.⁷ Cyclohexyllithium forms hexamer crystals for which multicenter bonding has been proposed.⁸ Methyl lithium forms tetramers with extended three-dimensional interactions in the solid state.⁹ Furthermore, polyolithiation of methane, to form CH₂Li₂,¹⁰ and even CLi₄,¹¹ and the fact that some alkyl lithium reactions have radical mechanisms¹² do not seem consistent with highly ionic carbon-lithium bonds.

Several theoretical studies of simple organolithium molecules have been reported. Methyl lithium monomer, dimer, and tetramer have been studied by minimal-basis ab initio calculations¹³⁻¹⁵ and by semiempirical MO methods.¹⁶ Ionicity vs. covalency in these molecules was examined using Mulliken population analyses.¹³⁻¹⁶ Electron-deficient bonding in the tetramer was evaluated with the use of electron-density plots.¹³ Vinyl lithium¹⁷ and phenyllithium¹⁸ have also been investigated by the CNDO method. Computations using a minimal Gaussian basis on cyclopentadienyllithium^{19,20} have also been reported. Ab initio calculations using large extended basis sets have been reported for lithium acetylide.²¹ Also germane to the discussion of bonding in organolithiums are the calculations of Astier and Millie²² on some methyl Grignard and related molecules.

The present study is the introduction to a series of ab initio investigations. In this paper we concentrate first on methyl lithium monomer and consider the series methyl-, ethyl-, vinyl-, and ethynyllithium, for comparison with related studies of the corresponding carbanions.²³ In subsequent papers we shall extend this study to alkyl lithium dimers and higher aggregates, polyolithiated compounds, and related organometallic compounds.

Methods of Calculation

Calculations were performed with four different basis sets. The simplest of these is the minimal STO-4G basis introduced by Hehre, Stewart, and Pople.²⁴ Orbital exponents for carbon and hydrogen are those found optimal for the corresponding hydrocarbon,²³ except for hydrogen on the carbon bound to lithium, for which the standard anion exponent (1.14) is used.²⁵ This choice gives somewhat lower energy than using the standard anion carbon exponent (1.56) for carbon bonded to lithium or using optimum hydrocarbon exponents throughout. The lithium exponent is 0.83, the optimum value for methyl lithium.²⁶ These calculations were performed using a modified version of IBMOL IV.²⁵

Extended basis calculations were performed using a Gaussian split-shell (SS) basis generated from the 8s4p functions for carbon, the 8s functions for lithium and 4s functions for hydrogen of Huzinaga,²⁷ and a 4p set for lithium optimized for the ²P state of the lithium atom.²⁸ These functions are contracted to 4s2p on C, Li, and 2s on H as before.^{23,28} To this basis we added a set of 3d orbitals on carbon, of exponent 0.8 for methyl, ethyl, and vinyl compounds, and 1.0 for ethynyl,²³ giving the SS+d basis, to which most of our discussions refer. For methyl- and ethynyllithium, SS+d,p calculations, incorporating p orbitals of exponent 1.0 on hydrogen into the SS+d basis, were also performed, but were found to give results essentially the same as those using the SS+d basis alone.

Results and Discussion

Geometric Structure. Extensive geometry optimizations were carried out for methyl lithium and ethynyllithium with three basis sets. The results are summarized in Table I. The minimal basis gives significantly shorter C-Li bonds than the extended basis sets. However, a basis with 2p orbitals on Li is not really minimal and is undoubtedly overweighted toward Li. Such a basis with first row atoms gives unrealistically high amounts of π bonding to Li.²⁸ Nevertheless, with a large STO basis an essentially Hartree-Fock result of Veillard for ethynyllithium with assumed CC and CH bond distances gives a C-Li distance of 1.880 \AA ,²¹ which is between our minimum basis and extended basis results.

Our calculated C-Li bond length for methyl lithium is slightly smaller than the value of 2.10 \AA estimated empirically⁵ and is expected to be substantially smaller than the C-Li distance of 2.31 \AA found experimentally for the tetramer.⁹ Our SS+d computed²⁹ force constant for CH₃Li in its optimized geometry, 0.99 mdyn \AA^{-1} , and the dipole moment, 5.90 D, agrees well with Andrews' results for the matrix-isolated monomer, 0.78 mdyn \AA^{-1} and 6 D, respectively.⁵

Table I. Optimized Geometries for Methyl- and Ethynyllithium

Molecule	Geometry parameter	Basis set		
		STO-4G ^a	SS	SS+d
CH ₃ Li	C-Li, Å	1.969	2.032	2.021
	C-H, Å	1.122	1.092	1.089
	HCH, deg	104.2	107.1	105.8
HC≡CLi	C-Li, Å	1.862	1.921	1.931
	C-C, Å	1.213	1.219	1.208
	C-H, Å	1.070	1.056	1.056

^a Optimized exponents: CH₃Li: C (2s), 1.71; Li (2s, 2p), 0.83; H, 1.12. HC_βC_αLi: C_β (2s, 2p), 1.67; C_α (2s, 2p), 1.66; H, 1.29; Li (2s, 2p), 0.74. Inner shell exponents used were not optimized and were taken as C (1s), 5.7, Li (1s), 2.69 for CH₃Li and C (1s), 5.67, Li (1s), 2.69 for LiC₂H.

Table II. Computed Total Energies for the Organolithium Molecules^a

Molecule	Geometry ^b	Basis set			
		STO-4G	SS	SS+d	SS+d,p
CH ₃ Li	ref ^c	-47.0024	-47.0139	-47.0200	-47.0200
	opt	-46.7767	-47.0026	-47.0147	-47.0206
C ₂ HLi	ref ^d	-83.2352	-83.6703	-83.6968	-83.6995
	opt	-83.2395	-83.6710	-83.6969	-83.6995
C ₂ H ₃ Li	ref ^e	-84.8317	-84.8597		
C ₂ H ₅ Li	ref ^c	-86.0081	-86.0383		

^a Energies in au (1 au = 627.502 kcal mol⁻¹). ^b ref = reference geometry, opt = energy-optimized value (see text). ^c CLi = 2.02 Å, optimal for CH₃Li. ^d CLi = 1.93 Å, optimal for C₂HLi. ^e CLi = 1.98 Å, average of optimum values for CH₃Li and C₂HLi.

The CC and CH bonds in ethynyllithium are essentially the acetylene values. It is known experimentally that the acetylene CC bond length of 1.203 Å³⁰ changes insignificantly in the carbide ion, C₂²⁻ (Na₂C₂, 1.200 ± 0.006 Å;³¹ CaC₂, 1.191 ± 0.009 Å).³²

A minimal basis set optimization of the C-Li length in ethyllithium without concurrent exponent optimization gives a distance of 2.04 Å,³³ essentially the same as the SS and SS+d results for CH₃Li.

It should also be emphasized that the total energies vary but little with C-Li distance and that the accurate determination of geometric parameters from such broad, flat potential surfaces is difficult if not impossible in any practically reasonable way. These small energy variations are apparent in the total energies summarized in Table II. The general and expected conclusion to be drawn from the results in Table I is that the carbon moieties in the lithium salts have geometries intermediate between hydrocarbon and carbanion. For convenience in subsequent electron density difference plots, calculations were also made for molecules in their "reference" geometry,²³ defined as the experimental geometry of the corresponding neutral hydrocarbon with one hydrogen removed and replaced by lithium at an appropriate bond distance but with the hydrocarbon bond angle.

The Carbon-Lithium Bonding in Methylithium. In previous ab initio studies of methylithium monomer¹³⁻¹⁵ the Mulliken atomic and overlap populations were used as criteria for covalent bonding. For example, the SS+d basis set for the reference geometry gives a C-Li overlap population of 0.603, a rather high number. For comparison, the C-C bond in ethane has an overlap population in the same basis of 0.628. This comparison naively suggests that the two bonds have comparable covalency but other considerations indicate that such a conclusion is totally fallacious.

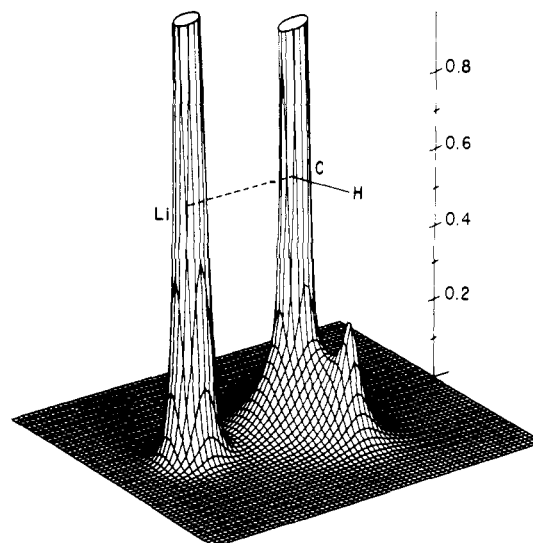

Figure 1. Total electron density in units of $e \text{ au}^{-3}$ plotted as the vertical axis for a LiCH plane, taken as the grid plane, for methylithium. In the structure superimposed above the electron density plot, the short dotted line refers to C-H bonds of the methyl group above and below the chosen molecular plane; SS+d basis.

The covalent bond requires shared electron density between the atoms.³⁴ Electron density and density-difference contour plots have been used extensively, particularly with respect to diatomic molecules, for detailed descriptions of bonds.^{35,36} Figure 1 shows a perspective plot of the total electron density for methylithium (SS+d basis) in a plane defined by Li, C, and one H. Especially striking in this plot is the relative absence of a ridge of electron density between C and Li, particularly by comparison with the C-H bonding region. The minimum value of the density along the C-Li internuclear line is 0.038 $e \text{ au}^{-3}$ compared with 0.275 $e \text{ au}^{-3}$ for C-H. The latter magnitude is typical for highly covalent bonds such as CC and CH. Moreover, even the small ridge observed for C-Li is probably not associated with covalent bonding. Such a ridge is a necessary but not sufficient condition for bonding since overlap of inner shell electrons (as in He-He) can produce such a ridge. The valence electron plot (electron density with the C and Li 1s orbital densities, 1 σ and 2 σ , deleted; not shown) shows a much reduced internuclear density; the minimum value of the valence electron density along the C-Li line is now only $2 \times 10^{-5} e \text{ au}^{-3}$.

This result emphasizes again^{28,37,38} the important limitations of Mulliken populations, particularly when the basis includes diffuse orbitals. The defined "overlap population" measures total overlap of two wave functions everywhere in space and *not just in the internuclear region*. Similarly, the "atomic population" with diffuse orbitals takes electron populations close to one atom and "assigns" them to another. In the present case, the Li 2s and 2p orbitals are so diffuse they encompass the entire molecule; hence, any population analysis based on atom-centered basis functions will assign to lithium electrons that are actually in the C-H spatial region. These generalizations are documented by the Mulliken populations summarized in Table III. Note the changes in assignments given by the three largest basis sets despite the small actual change in electron distribution as shown by the calculated dipole moments. Especially revealing are the atomic charge changes, *even on Li*, on adding p functions to H.

The electron density criterion leads to the conclusion that the C-Li bond has essentially nil covalent character. The SS+d basis is a reasonably good one and it seems unlikely that this conclusion would differ at the Hartree-Fock limit. To the next question of whether electron correlation would significantly

Table III. Mulliken Populations for CH₃Li^a

Basis	Overlap populations		Atomic charges			μ, D
	C-Li	C-H	C	Li	H	
STO4G	0.620	0.765	-0.066	+0.191	-0.042	4.77
SS	0.572	0.710	-1.034	+0.578	+0.152	5.80
SS+d	0.603	0.723	-1.034	+0.560	+0.158	5.85
SS+d,p	0.611	0.747	-0.847	+0.555	+0.098	5.84

^a For a methanelike geometry with $r(\text{CLi}) = 2.02 \text{ \AA}$.

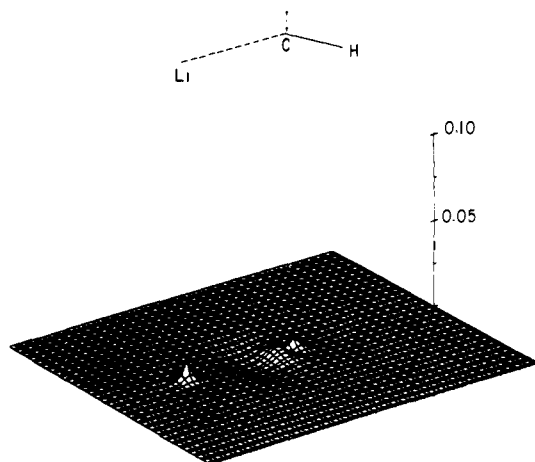

Figure 2. Difference density plot for CI electron density and SCF density for CH₃Li with the SS basis, $\rho(\text{CI}) - \rho(\text{SCF})$; SS basis.

affect this conclusion, we apply a limited CI study. The configuration-interaction calculation included double and single excitation from the $\sigma(\text{CLi})$ MO and the three lowest lying occupied MO's of the same a_1 symmetry to all of the virtual MO's of a_1 symmetry having significant contributions from lithium AO's. Because of programming limitations, this calculation was done using the SS basis set, that is, with no polarization functions on carbon. The total number of configurations was 36, and the resulting CI wave function was transformed to natural orbitals.³⁹ The highest occupied MO is predominantly C whereas the lowest a_1 virtual MO is heavily weighted by Li; hence, the CI part of the wave function is heavily dominated by excitation between the highest occupied and lowest vacant MO's or by charge transfer from C to Li. The energy lowering obtained is 0.01301 au (8.2 kcal mol⁻¹), a rather modest improvement.

A plot of the difference between the density given by the CI wave function and that of the SS basis is given in Figure 2. The mixing in of the C-Li antibonding MO's has moved a small amount of density from the carbon front- and back-lobe regions of the CLi bond pair into lithium and carbon nuclear regions. The resultant bond-pair density also moves closer to carbon. The natural orbital occupation numbers show that the natural orbital having the greatest $\sigma(\text{CLi})$ MO character has lower electron population, from 2.0 electrons in the SCF to 1.96 electrons in the CI function, and 0.03 electrons are in the orbital most like the $\sigma^*(\text{CLi})$. The changes are small and do not affect the conclusions derived above concerning the absence of C-Li covalency; a more complete CI is unlikely to modify the conclusions significantly.

Electron density functions can be exceedingly useful especially in the comparisons afforded by difference density plots. For example, a criterion for covalency in diatomic molecules in terms of molecular minus atomic density difference plots has been proposed:^{35c} that the molecule should show a charge increase, more or less equally shared by both atoms, in the internuclear region, relative to its constituent atoms. The

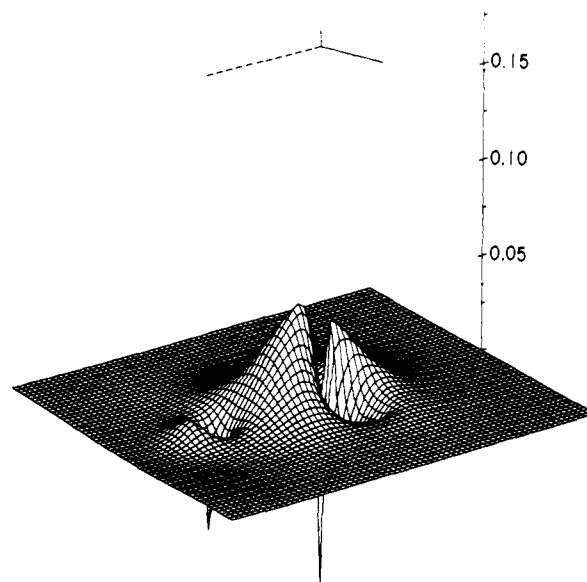

Figure 3. Radical difference density plot for methyl lithium, $\rho(\text{CH}_3\text{Li}) - \rho(\text{CH}_3\cdot) - \rho(\text{Li}\cdot)$, for a HCLi plane. The $\rho(\text{CH}_3\cdot)$ was obtained from ref 23. The scale of $e \text{ au}^{-3}$ is about five times that of Figure 1; SS+d basis.

equivalent difference function for CH₃Li is the "radical difference" plot shown in Figure 3, a plot of $\rho(\text{CH}_3\text{Li}) - \rho(\text{CH}_3\cdot) - \rho(\text{Li}\cdot)$, for a methyl radical²³ and lithium atom constrained to the same geometry as CH₃Li. This plot shows the change in electron density for a HCLi plane when the electrons of an isolated Li atom and pyramidal methyl radical are allowed to relax to form CH₃Li. Figure 3 shows a large charge increase in the CLi internuclear region but *not shared by both atoms*. Indeed, the change is about that expected for the formation of CH₃⁻ and Li⁺ except that the degree of charge transfer appears notably asymmetric; the electron density gain in the carbanion lone pair region appears greater than loss from Li *for the plane shown*. For considerations of total atomic charges and charge transfer we need to consider the volumes involved and would prefer to have integrated functions over such volumes rather than just electron *density* changes alone.

We have recently proposed⁴⁰ an electron projection function, P_{xz} , in which, for a given point x, z , the electron density is integrated along the y axis from $+\infty$ to $-\infty$. The resulting function can be displayed in the xz plane in contour or perspective form and has the advantage that apparent volume elements are now directly related to electron populations; that is, the volume of the entire figure gives directly the total number of electrons in the molecule. Figure 4 displays the electron projection function for CH₃Li for a plane parallel to a LiCH plane. This figure again shows the absence of electron population between C and Li, especially compared to C-H. In principle, this figure could be used to derive electron populations and atomic charges for each of the atoms but in practice such an assignment is difficult for C and H. The P_{xz} function between these atoms is so continuous and monotonic that the

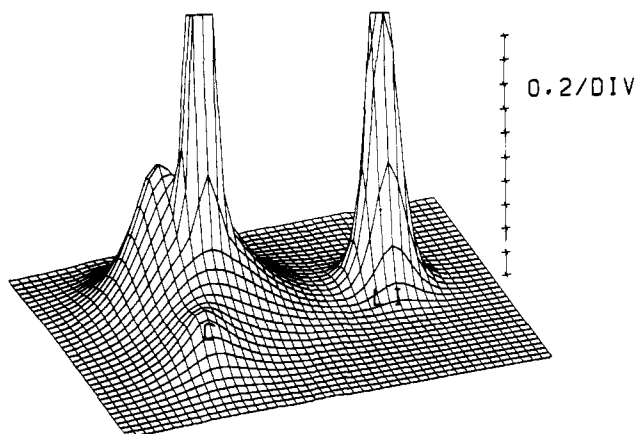

Figure 4. Projection function, P_{xz} , for methyllithium in a HCLi plane; SS basis.

choice of where C ends and H begins is rather arbitrary.⁴¹ No such problem exists for the C-Li bond. The dramatic minimum between these atoms allows clear-cut assignment of electron populations to Li and to the CH_3 group.

Approximate spatial electron populations were derived by numerical integration of Figure 4 using the grid points as centers of area elements. The result may be referred to as an integrated population, P_e (electron population). The P_e of the entire Figure 4 is 12.06 e, in which the excess of 0.06 e is the error associated with this numerical integration using a rather coarse grid of 0.2 au spacing. We have found such errors to be generally less than 0.1 e. The total P_e to be assigned spatially to the methyl group as a unit, up to the minimum between C and Li, is 9.90 e. The corresponding population of Li is 2.16 e; thus, the spatial distribution of electrons in CH_3Li corresponds largely to a CH_3^-Li^+ ion pair. For comparison, we have made similar plots for $\text{CH}_3^- + \text{Li}^+$, $\text{CH}_3\cdot + \text{Li}\cdot$, as well as for CH_3^- , $\text{CH}_3\cdot$, Li^+ , and $\text{Li}\cdot$, with the atoms placed on the grid exactly at their positions in CH_3Li in Figure 4. The corresponding P_e 's summarized in Table IV include dissections into the same CH_3 and Li regions derived from Figure 1. Note that CH_3^- , $\text{CH}_3\cdot$, and Li^+ are all well behaved in the sense that their P_e 's lie almost wholly within the grid regions derived from Figure 4. Lithium atom, however, is so diffuse that its electrons overflow beyond the grid limits used, almost 0.3 e lie outside the grid and another 0.3 e lie in the region assigned spatially to methyl. The lithium P_e in CH_3Li is much more like Li^+ than $\text{Li}\cdot$. Finally, we have examined several ΔP_e plots in which P_{xz} for various combinations of ionic and radical structures are compared with P_{xz} for CH_3Li ; that is, eq 1 in which $0 \leq x \leq 1$.

$$\Delta P_{xz} = P_{xz}(\text{CH}_3\text{Li}) - x[P_{xz}(\text{CH}_3^-) + P_{xz}(\text{Li}^+)] - (1-x)[P_{xz}(\text{CH}_3\cdot) + P_{xz}(\text{Li}\cdot)]$$

All such difference plots should have total $\Delta P_e = 0$ and for the plots of interest the total integrated values determined numerically are < 0.1 e. If CH_3Li were exactly like some combination of CH_3^-Li^+ and $\text{CH}_3\cdot\text{Li}\cdot$ the resulting ΔP_{xz} plot would be a flat plane for that value of x . In practice, the minimum difference function is given for $x = 0.8$. At this value the total $\Delta P_e(\text{CH}_3) = 0.03$ e and $\Delta P_e(\text{Li}) = 0$.

The result of the foregoing analysis can be summarized with the resonance structures,

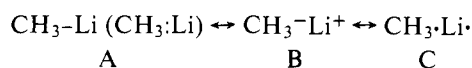

Structure A is the shared-electron structure required for covalent bonding.^{34,35,42} The present results show this structure to contribute negligibly to CH_3Li . Structure B is the ionic

Table IV. Integrated Populations

System	"Methyl region"	"Lithium region"	Total
CH_3Li	9.90	2.16	12.06
$\text{CH}_3\cdot + \text{Li}$	9.39	2.44	11.83
$\text{CH}_3^- + \text{Li}^+$	9.99	2.08	12.07
CH_3^-	9.97	0.09	10.06
$\text{CH}_3\cdot$	9.08	0.04	9.12
Li^+	0.02	1.99	2.01
$\text{Li}\cdot$	0.32	2.40	2.72
$\Delta P: \text{CH}_3\text{Li} - 0.8(\text{CH}_3^-\text{Li}^+) - 0.2(\text{CH}_3\cdot\text{Li}\cdot)$	0.03	0	0.03

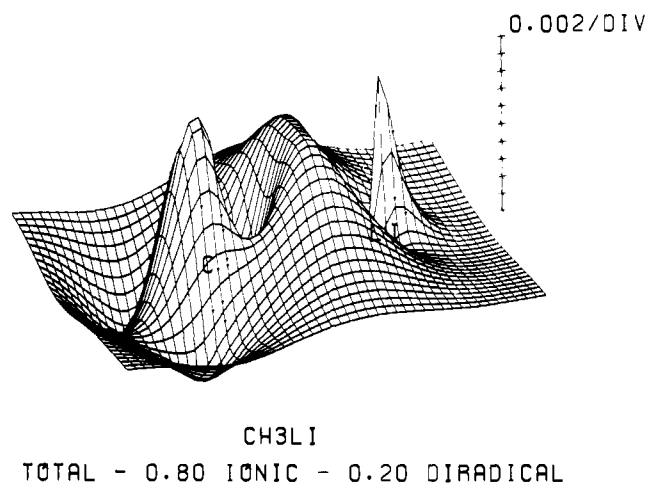
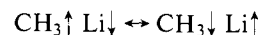

Figure 5. Difference projection function for methyllithium defined by eq 1 for $x = 0.8$. The total volume of the ΔP function for the methyl region is 0.03 e and for the lithium region 0.00 e. That is, for $x = 0.8$ the plot shows polarization within both groups but no charge transfer from one group to another. The vertical scale is about 10^2 that of Figure 4.

contribution and is dominant in CH_3Li . Structure C is that of a methyl radical and lithium atom in close juxtaposition and, except for the small overlap electron population inherent in such a structure that corresponds to A, contributes essentially no bonding. This structure can, however, account for the substantial $^{13}\text{C}-^7\text{Li}$ coupling constants observed for organolithium compounds^{6,7,43} because of the spin polarization implied by:



That is, such coupling constants are not necessarily indicative of covalent bonding.

The foregoing description of methyllithium in terms of ionic bonding involving partial charge transfer differs little from Mulliken's treatment of charge-transfer complexes.⁴⁴ Thus, methyllithium may be described as a charge transfer complex with substantial but not complete (~ 0.8 e) charge transfer. It differs from such compounds as LiF only in that LiF involves almost complete charge transfer^{35b} and, unlike CH_3^- , the free fluoride ion is spherical. Nevertheless, the degree of charge transfer in monomeric CH_3Li appears to be much greater than considered heretofore on the basis of Mulliken populations¹³⁻¹⁵ and on NMR studies of alkylolithiums.⁶

Finally, we should also mention the degree to which methyl and lithium are polarized by each other. Such polarization is shown graphically by the ΔP_{xz} plot in Figure 5 for eq 1, $x = 0.8$. The polarization is shown by the asymmetry of the difference populations about carbon and lithium. For example, numerical integration of Figure 5 shows that a total of about 0.1 e is transferred from the CH region behind C to the region between C and Li.

Table V. Some Properties of C-Li Bonds^a

Bond R-Li	$r(\text{C-Li})$, Å	CLi density minimum total (valence)	$\epsilon_{\text{MO}}(\text{CLi})^b$ au	$P_m(\text{CLi})^c$	$q(\text{Li})^d$	μ, D
H ₃ C-Li	2.02	0.038 ($\sim 10^{-3}$)	-0.270	0.603	+0.559	5.85
H ₅ C ₂ -Li	2.02	0.039 ($\sim 10^{-3}$)	-0.254	0.616	0.572	5.75
H ₃ C ₂ -Li	1.98	0.041 ($\sim 10^{-3}$)	-0.289	0.562	0.607	6.10
HC ₂ -Li	1.93	0.040 ($\sim 10^{-3}$)	-0.413	0.291	0.715	6.24

^a Computed using SS+d basis for molecules in reference geometries. ^b Orbital energy in au of the MO with highest percentage of C-Li bond character, i.e., approximately $\sigma(\text{C-Li})$. ^c Mulliken overlap population. ^d Charge on Li from Mulliken atomic population.

Table VI. Some Energy Properties of Organolithium Compounds

R in RLi	Dissociation energies ^a				$\Delta E(\sigma \rightarrow \sigma^*)^c$	$\Delta E(\text{lith})^e$
	(R ⁻ , Li ⁺)	(R ⁻ , H ⁺)	(R [•] , Li [•])	(R [•] , H [•]) ^b		
CH ₃	192	453	24	93 (104)	35	69
C ₂ H ₅	187	453	17	90 (98)	<i>d</i>	73
C ₂ H ₃	181	438	33	97 (108)	46	64
C ₂ H	170	396	83	116 (122)	108	33

^a All systems in reference geometries, SS+d basis, energies in kcal mol⁻¹. The symbol $D(A, B)$ is the calculated energy for the process $\text{AB} \rightarrow \text{A} + \text{B}$. ^b Experimental ΔH° values in parentheses (D. M. Golden and S. W. Benson, *Chem. Rev.*, **69**, 125 (1969); S. W. Benson, personal communication. ^c Singlet-to-triplet electronic excitation energy in kcal mol⁻¹ from CLi bonding MO to the CLi antibonding MO. ^d This quantity was not computed, but will presumably be less than 35 kcal mol⁻¹, just as $D(\text{R}^\bullet, \text{H}^\bullet)$ is less than that for CH₃Li. ^e Hydrocarbon lithiation energies in kcal mol⁻¹ for the reaction $\text{RH} + \text{Li} \rightarrow \text{RLi} + \text{H}$.

CLi Excitation, Homolysis, and Oligomer Bonding. As discussed above, CLi bonding in CH₃Li is primarily ionic but because methyl radical has such low electron affinity the energy required to transfer an electron back from carbon to lithium should be relatively low. The calculated energy for the $\sigma(\text{CLi}) \rightarrow \sigma^*(\text{CLi})$ transition, which transfers an electron from the $\sigma(\text{CLi})$, localized mainly on carbon, to σ^* , localized mainly on lithium, is indeed rather low, about 1.5 eV for the singlet-to-triplet transition. From the CI calculation discussed above the energy difference between the ground state and first excited eigenfunction of the CI secular determinant, corresponding to the $\sigma(\text{CLi})$ to $\sigma^*(\text{CLi})$ singlet-to-singlet excitation energy, is almost twice as high, 2.8 eV, but is still fairly small.

Experimentally, alkyllithiums in the vapor phase have uv absorptions in the 190–215 nm (6.25–5.76 eV) range.⁴⁶ This is considerably larger than our value for monomeric CH₃Li, but it is highly likely that as the alkyllithium oligomerizes, the energy of the CLi $\sigma \rightarrow \sigma^*$ transition will increase. This effect is found for CH₃Li monomer and dimer in minimal basis calculations.²⁶

The calculated energy for dissociation of CH₃Li into lithium atom and methyl radical is only 0.84 eV (SS+d basis, optimum CH₃Li geometry, planar CH₃). This value will increase if the correlation energy of the CLi bond pair is considered. This correlation correction could be as high as 2.3 eV, the correlation energy correction for the process $\text{CH}_3^- \rightarrow \text{CH}_3^\bullet + \text{e}$, as given by comparing the SS+d calculation to an experimental estimate.²³ However, pair correlation energies in neutral closed-shell molecules are usually about half this value or ~ 1 eV,³⁹ and CH dissociation energies computed with the SS+d basis are typically too low by 0.5 eV or less. Thus, the dissociation energy of CH₃Li monomer is expected to be less than 2–3 eV (45–70 kcal mol⁻¹). Experimental data give a CLi dissociation energy of 50.5 kcal mol⁻¹ for gaseous ethyllithium, presumably tetrameric or hexameric (see ref 14 for data). This value should be reduced by the amount of oligomerization energy.

These results indicate that either by electronic transition to a low-lying excited state, or by the evidently lower-energy process of direct CLi homolysis, radical species can be formed

readily. Radicals are often found in reactions of organolithium reagents.^{7a}

Although a study of alkyllithium oligomers will be presented in a subsequent paper, a brief mention is included here because the surprising finding of large charge transfer in CH₃Li monomer and the absence of covalent C-Li bonding differs so radically from the multicenter bonding observed in many alkyllithium oligomers and assumed to involve covalent interactions (vide supra). We may now anticipate that the driving force for oligomerization will be largely that of ionic aggregation-Madelung type interactions. The unimportance of CLi overlap in these systems means that the oligomer bonding will *not* be significantly multicenter covalent as found, for example, in diborane, where orbitals from three centers simultaneously share a pair of bonding electrons.⁴⁷

This view is in complete accord with the absence of significant Li-Li bonding in alkyllithium tetramers found from NMR coupling⁴⁸ and Raman⁴⁹ studies.

Other Alkyllithiums. Table V shows that ethyllithium is generally rather similar to methyllithium. Along the series ethyl, vinyl, ethynyl, however, the C-Li bond length becomes shorter and the energy of the C-Li bond MO decreases although there is little change in the values of the bond density minima. None of these compounds shows significant CLi covalency; the position of the electron density minimum is in all cases 0.63 ($r_{\text{C-Li}}$).

Some energy quantities for these molecules are given in Table VI. The CLi heterolysis energies (Table VI, column 1) decrease along the ethyl to ethynyl series, undoubtedly as a result of the increasing stabilities of the corresponding carbanions. This ordering, though not the relative magnitudes of the differences, is preserved in column 2 of Table VI, the carbanion proton affinities. This trend is reversed in the CLi and CH homolysis energies. Again, the more stable the anion, the more energy is required for back-transfer of charge from carbanion to lithium during CLi homolysis, or during the CLi $\sigma \rightarrow \sigma^*$ electronic transitions. These transition energies correlate linearly with CLi homolysis energies. Ethynyllithium is by far the most stable of the lithium salts, relative to the parent hydrocarbon (Table VI, last column). The stability of

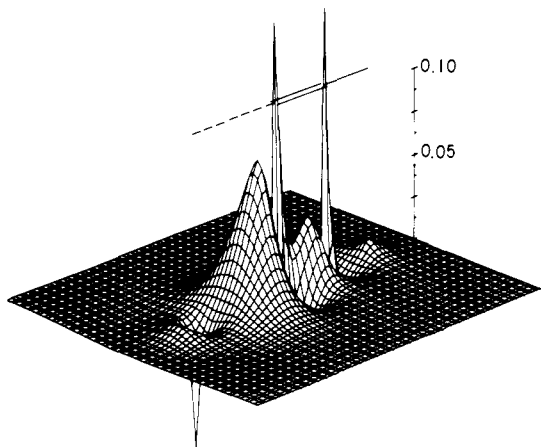

Figure 6. Electron density difference plot for formation of ethynyllithium from ethynyl radical and lithium atom at the same geometry; $\rho(\text{HC}_2\text{Li}) - \rho(\text{HC}_2) - \rho(\text{Li})$; SS+d basis set.

ethynyl anion indicates a relatively high contribution of ionic character.

The most striking and perhaps unexpected feature of Table VI is the jump between vinyl and ethynyl in each of the tabulated energy properties. The common denominator in these properties is the much lower energy of the MO composed of the anionic lone pair or anionlike CLi bond pair (Table V, column 5) in ethynyllithium compared to vinylithium or ethyllithium. To examine this difference more closely, we have examined the density difference plots. The change in electron density distribution on forming a CLi bond from vinyl radical and lithium atom is not reproduced here but is much the same in the CLi region as in the corresponding methylithium difference plot. There is a modest density gain at all hydrogens but the most marked feature is again the carbanion lone pair, resulting from charge transfer from lithium. There is also a large increase in electron density in the "back-lobe" region of the α carbon and a density loss of polarization from the perpendicular p-like region. These density changes are much the same as but of lower magnitude than those found for deprotonation of ethylene to give vinyl anion.²³ Correspondingly, the vinylithium ionic difference density plot, $\rho(\text{C}_2\text{H}_3\text{Li}) - \rho(\text{C}_2\text{H}_3^-) - \rho(\text{Li}^+)$, not reproduced here, shows these same changes but of smaller magnitude and with signs reversed.

The corresponding atomic or radical difference plot for ethynyllithium $\rho(\text{HC}_2\text{Li}) - \rho(\text{HC}_2) - \rho(\text{Li})$, is shown in Figure 6. Some features are common to the corresponding methylithium (Figure 3) and vinylithium difference plots. We see again the large carbanion lone pair mound and the corresponding density gain in the back-lobe region. However, the back-lobe region is now the C-C σ -bond region and can provide bond strengthening. The loss in density in the perpendicular p-like region is now in the π bond of the CC triple bond but the bonding loss that this implies is compensated by the gain in σ -bonding density. However, the most striking feature is the sharp spike at C_α which shows an *increase* in electron density at the nucleus in contrast to the *decrease* shown for vinylithium and methylithium. The difference undoubtedly results from differences in the amount of s character in the carbanion lone pair, and fits in with simple approximations in which the lone pair of methyl anion is considered to be roughly sp^3 , that of vinyl anion is about sp^2 , and that of ethynyl anion is sp . The relative stabilities of organolithium compounds do correlate with these approximate s characters of the corresponding carbanion lone pairs,³ and these results of electron density functions provide a further justification for the common use of estimates of relative carbanion stabilities based on bond

angles and s character and of relative organolithium stabilities based on the corresponding carbanions.

References and Notes

- (1) This research was supported in part by NSF Grant No. 29383, and USPH NIH Grant No. 12855. Additional computer time was provided by the Computer Center, UCB, and by the Nuclear Chemistry Division of the Lawrence Berkeley Laboratory.
- (2) For recent reviews, see J. M. Mallan and R. L. Bebb, *Chem. Rev.*, **69**, 693 (1969).
- (3) D. E. Applequist and D. F. O'Brien, *J. Am. Chem. Soc.*, **85**, 743 (1963).
- (4) For reviews, see G. E. Coates, M. L. H. Green, and K. Wade, "Organometallic Compounds", 3d ed, Vol. 1, Methuen and Co. Ltd., London, 1967, Chapter 1.; M. Schlosser, "Polare Organometalle", Springer-Verlag, Berlin, 1973; P. West, "MTP International Review of Science", Series 1, Vol. 4, B. J. Aylett, Ed., University Park Press, Baltimore, Md., 1972, p 1.
- (5) L. Andrews, *J. Chem. Phys.*, **47**, 4834 (1967).
- (6) L. D. McKeever, R. Waack, M. A. Doran, and E. B. Baker, *J. Am. Chem. Soc.*, **91**, 1057 (1969).
- (7) (a) T. L. Brown, *Adv. Organomet. Chem.*, **3**, 365 (1965); (b) *Acc. Chem. Res.*, **1**, 23 (1968).
- (8) R. Zenger, W. Rhine, and G. Stucky, *J. Am. Chem. Soc.*, **96**, 6048 (1974).
- (9) E. Weiss and G. Hencken, *J. Organomet. Chem.*, **21**, 265 (1970).
- (10) K. Ziegler, K. Nagel, and M. Patheiger, *Z. Anorg. Allg. Chem.*, **282**, 345 (1955); P. Krohmer and J. Goubeau, *ibid.*, **369**, 238 (1969); *Chem. Ber.*, **104**, 1347 (1971).
- (11) C. Chung and R. J. Lagow, *J. Chem. Soc., Chem. Commun.*, 1078 (1972).
- (12) H. Fischer, *J. Phys. Chem.*, **73**, 3834 (1969).
- (13) M. F. Guest, I. H. Hillier, and V. R. Saunders, *J. Organomet. Chem.*, **44**, 59 (1972).
- (14) N. C. Baird, R. F. Barr, and R. K. Datta, *J. Organomet. Chem.*, **59**, 65 (1973).
- (15) N. J. Fitzpatrick, *Inorg. Nucl. Chem. Lett.*, **10**, 263 (1974).
- (16) G. R. Peyton and W. H. Glaze, *Theor. Chim. Acta.*, **13**, 259 (1969); A. H. Cowley and W. D. White, *J. Am. Chem. Soc.*, **91**, 34 (1969); K. Ohkubo, H. Shimada, and M. Okada, *Bull. Chem. Soc. Jpn.*, **44**, 2025 (1971).
- (17) J. Kriz, *J. Polym. Sci., Part A-2*, **10**, 615 (1972).
- (18) A. Streitwieser, Jr., P. C. Mowery, R. G. Jesialitis, J. S. Wright, P. H. Owens, and D. M. E. Reuben, *Proc. Sect. Sci., Isr. Acad. Sci. Humanit.*, 160 (1970).
- (19) H. Preuss and R. Janoschek, *J. Mol. Struct.*, **3**, 423 (1969).
- (20) R. Janoschek, G. Dierksen, and H. Preuss, *Int. J. Quantum Chem.*, **1S**, 205 (1967).
- (21) A. Veillard, *J. Chem. Phys.*, **48**, 2012 (1968).
- (22) M. Astier and P. Millie, *J. Organomet. Chem.*, **31**, 139 (1971).
- (23) J. E. Williams, Jr., and A. Streitwieser, Jr., *J. Am. Chem. Soc.*, **97**, 2634 (1975).
- (24) W. J. Hehre, R. F. Stewart, and J. A. Pople, *J. Chem. Phys.*, **51**, 2657 (1969).
- (25) P. H. Owens and A. Streitwieser, Jr., *Tetrahedron*, **27**, 4471 (1971).
- (26) J. Cambray, unpublished results.
- (27) S. Huzinaga, D. McWilliams, and B. Domsy, *J. Chem. Phys.*, **54**, 2283 (1971); S. Huzinaga, *ibid.*, **42**, 1293 (1965).
- (28) J. E. Williams and A. Streitwieser, Jr., *Chem. Phys. Lett.*, **25**, 507 (1974).
- (29) The force constant was calculated from the variation of total energy with C-Li bond distance, keeping the methyl group intact; hence, the calculated force constant does not correspond to a true normal mode of vibration.
- (30) E. H. Plyler and E. D. Tidwell, *J. Opt. Soc. Am.*, **53**, 589 (1963); W. J. Lafferty and R. J. Thibault, *J. Mol. Spectrosc.*, **14**, 79 (1964).
- (31) M. Atoji, *J. Chem. Phys.*, **60**, 3324 (1974).
- (32) M. Atoji, *J. Chem. Phys.*, **35**, 1950 (1961).
- (33) J. E. Williams, Jr., and A. Streitwieser, Jr., unpublished results.
- (34) (a) K. Ruedenberg, *Rev. Mod. Phys.*, **34**, 326 (1962); (b) W. Kutzelnigg, *Angew. Chem., Int. Ed. Engl.*, **12**, 546 (1973).
- (35) (a) C. W. Kern and M. Karplus, *J. Chem. Phys.*, **40**, 1374 (1964); (b) R. F. W. Bader and W. H. Henneker, *J. Am. Chem. Soc.*, **87**, 3063 (1965); (c) R. F. W. Bader, W. H. Henneker, and P. E. Cade, *J. Chem. Phys.*, **46**, 3341 (1967); (d) R. F. W. Bader, I. Keaveny, and P. E. Cade, *ibid.*, **47**, 3381 (1967); (e) P. E. Cade, R. F. W. Bader, W. H. Henneker, and I. Keaveny, *ibid.*, **50**, 5313 (1969).
- (36) A number of examples may be found in A. Streitwieser, Jr., and P. H. Owens, "Orbital and Electron Density Diagrams", Macmillan, New York, N.Y., 1973.
- (37) P. Politzer and R. R. Harris, *J. Am. Chem. Soc.*, **92**, 6451 (1970).
- (38) (a) R. S. Mulliken, *J. Chem. Phys.*, **36**, 3428 (1962); (b) E. R. Davidson, *ibid.*, **46**, 3320 (1967); (c) E. W. Stout, Jr., and P. Politzer, *Theor. Chim. Acta*, **12**, 379 (1968).
- (39) H. F. Schaefer, III, "The Electronic Structure of Atoms and Molecules", Addison-Wesley, Reading, Mass., 1972, Sections I.C and II.D.
- (40) A. Streitwieser, Jr., and J. M. McKelvey, *Chem. Phys. Lett.*, submitted.
- (41) Although attempts have been made to define such limits, two examples are ref 37 and R. F. W. Bader and P. M. Beddall, *J. Am. Chem. Soc.*, **95**, 305 (1973). Our use of the minimum in ρ or P_{xz} to mark the demarcation between C and Li corresponds to the definition of Bader and Beddall. Politzer and Harris (ref 37) base their definition on the isolated atoms and would assign a higher population to the Li of methylithium than our definition.
- (42) L. Pauling, "The Nature of the Chemical Bond", 3d ed, Cornell University Press, Ithaca, N.Y., 1970, p 7.
- (43) M. A. Weiner and R. West, *J. Am. Chem. Soc.*, **85**, 485 (1963); G. E. Hartwell and T. L. Brown, *ibid.*, **88**, 4625 (1966); F. Schue and S. Bywater, *Macromolecules*, **2**, 458 (1969).
- (44) R. S. Mulliken, *J. Chim. Phys. Phys.-Chim. Biol.*, **61**, 20 (1964); R. S. Mulliken and W. B. Person, "Molecular Complexes", Wiley-Interscience, New York,

- N.Y., 1969, especially Chapter 13.
 (45) Cf. ref 23 and references cited therein.
 (46) J. B. Smart, R. Hogan, P. A. Scherr, L. Ferrier, and J. P. Oliver, *J. Am. Chem. Soc.*, **94**, 8371 (1972).
 (47) E. Switkes, R. M. Stevens, W. N. Lipscomb, and M. D. Newton, *J. Chem.*

- Phys.*, **51**, 2085 (1969).
 (48) T. L. Brown, L. M. Seitz, and B. Y. Kimura, *J. Am. Chem. Soc.*, **90**, 3245 (1968).
 (49) W. M. Scovell, B. Y. Kimura, and T. G. Spiro, *J. Coord. Chem.*, **1**, 107 (1971).

Mechanism of the Wolff Rearrangement. 6. Ab Initio Molecular Orbital Calculations on the Thermodynamic and Kinetic Stability of the Oxirene Molecule

O. P. Strausz,*^{1a} R. K. Gosavi,^{1a} A. S. Denes,^{1b} and I. G. Csizmadia^{1b}

*Contribution from the Departments of Chemistry, University of Alberta, Edmonton, Canada, and University of Toronto, Toronto, Canada.
 Received June 23, 1975*

Abstract: A nonempirical SCF molecular orbital study using double- ζ quality basis set has been carried out on oxirene and its isomeric ketocarbene, the formylmethylene molecules with full optimization of the geometrical parameters. The total energy of the ground-state oxirene lies 11.8 kcal/mol above ground-state ketocarbene. The reaction path for the interconversion of the two species has also been studied with partial optimization of geometrical parameters. The ring opening reaction of oxirene to yield ketocarbene features an activation energy of 7.3 kcal/mol.

Oxirene and its methyl- and phenyl-substituted derivatives have been shown in recent years to have transient existence and to be implicated as short-lived reactive intermediates in the photolytic and high-temperature thermal decomposition of diazo ketones and ketenes.² The low-temperature thermal decomposition of these molecules, on the other hand, which in most cases leads to the same final products, proceeds via a different reaction path by-passing the oxirene structure. This general kinetic behavior was interpreted as a clear indication that oxirene formation is associated with the presence of excess energy in the reacting system, suggesting that it is thermodynamically less stable than its isomeric ketocarbene. This conclusion appeared to gain further support from theoretical studies. Extended Hückel molecular orbital calculations³ predicted approximately 30 kcal/mol higher energies for oxirene and mono- and dimethyloxirene than for their corresponding isomeric ketocarbene. Also, oxirene and its methyl derivatives were predicted to be inherently unstable with respect to C-O bond cleavage and to exist only as short-lived transients, for their isomerization to ketocarbene was calculated to have zero activation energy.

Further theoretical studies by Hopkinson⁴ and Dewar and Ramsden⁵ culminated in results which were in conflict with the above picture. Thus, Hopkinson, using an ab initio SCF-MO method with a minimum basis, concluded that oxirene is 0.4 kcal/mol more stable than its isomeric formylmethylene, while Dewar and Ramsden from their semiempirical MINDO/3 and NDDO methods computed oxirene to be 18.2 and 20.6 kcal/mol, respectively, more stable than formylmethylene.

The question of the stability of oxirene is of considerable significance on its own merit and also with regards to the mechanistic details of the Wolff decomposition-rearrangement sequence and the decomposition of ketenes. For these reasons we have undertaken another more reliable nonempirical SCF-MO study of the problem using a double- ζ quality basis set.

Method

The individual atomic orbitals used were built up by contraction from 80 primitive Gaussian-type functions (GTF),

and the molecular orbitals were obtained from a 34 contracted double- ζ quality s, p basis set by linear transformation. The basis orbitals associated with the carbon and oxygen ((9s,5p) contracted to [4s,2p]) and hydrogen atoms ((4s) contracted to [2s]) are those originally suggested by Dunning.⁶ The Roothaan-type SCF-MO computations⁷ were carried out on an IBM 360/67 computer using the IBMOL-IV system.⁸ Total energy values associated with the lowest singlet- and triplet-excited configurations of oxirene were computed by the virtual orbital technique.⁹

The geometry optimization was carried out in successive steps. One bond length or one bond angle was varied at a time. To three computed points, along a given mode, a quadratic equation was fitted in order to find the minimum. This fitted minimum point was recomputed in another SCF-MO calculation and that point also served as the first point for the optimization along the next geometrical parameter.

Results and Discussion

The total state energies for the singlet ground state of oxirene and formylmethylene were computed with the full optimization of the geometrical parameters. The results along with the lowest vertical triplet-state energies and dissociation products, C₂H₂ plus O(³P) and O(¹D₂) energies are summarized in Figure 1. The fully optimized geometrical configuration of oxirene lies 11.8 kcal/mol above the fully optimized geometry of formylmethylene. Since the present computation is much more sophisticated¹⁰ than the previous ones and the results are in agreement with all experimental observations on the kinetic features of the oxirene-forming reactions, we conclude that oxirene is thermodynamically less stable than its isomeric ketocarbene, formylmethylene. This result agrees, at least in the qualitative sense, with the earlier extended Hückel calculations, which gave approximately 30 kcal/mol for the stability difference for oxirene and formylmethylene and slightly larger values for mono- and dimethyloxirene. On this basis we also conclude that methyl- and dimethyloxirenes are also thermodynamically less stable than their corresponding ketocarbenes. Thermodynamic instability, of course, does not preclude the possibility of kinetic stability. The earlier extended Hückel calculations, however, predicted no kinetic